



RANGEMAX FRONT BUMPER

2022+ TOYOTA TUNDRA



INSTALL GUIDE

PLEASE READ ENTIRE GUIDE BEFORE INSTALLATION

Recommended that you read this entire install guide before installation. Check that all hardware is present before starting or scheduling an install. This guide is supplemental to mechanical knowledge and ability. Anyone not familiar with automotive installation should seek professional installation.

LAST UPDATE 6/24/24 v2



INSTALL GUIDE

IMPORTANT INFO/FAQ

INSTALL GUIDE

ALL

INSTALLATION HELP

Please review terms and conditions for details

Recommended purchaser review Welcome Guide at time of purchase for details

Care and Maintenance available at www.exp-one.com/resources

We do our best to offer timely assistance with your installation questions however as most of our team members are primarily engaged in the manufacturing process and packaging processes, we do not currently offer a tech for on-demand calls and inquiries. For the more technical installs or installs that are time-sensitive in nature, we would recommend our customers seek out the services of professional shops with experience specific to aftermarket bumpers that can better meet your needs. We are happy to make recommendations to you on shops familiar with our products in your area. We do our best to respond to installation questions within 24-48 hours of contact as much as possible. Long-distance problem assessment can be difficult, so photos and videos are often required for us to best assist you. We highly recommend your initial contact regarding installation questions include both close-up and full photos, detailed descriptions using our part descriptions as much as possible, and video. This enables us to better assist without having the ability to see the install difficulties directly and assist you as quickly as possible.

NOTE

Expedition One does not guarantee fitment with other aftermarket products, or reinstallation of take off OEM parts.

Expedition One is NOT RESPONSIBLE for damage to paint or powder coating, items assembled in error during installation or costs associated with install

OEM manufacture model refreshes/updates, factory build location and suppliers may cause variations in fitment or installation and can not be verified, vehicle to vehicle .

This product contains chemicals known to the state of California to cause birth defects or other reproductive harm. For more information go to www.p65warnings.gov

GSA# GS-30F-013CA

EXPEDITION ONE
113 N. 700 W. BUILDING 5C BAY 1
OGDEN, UT 84404
INFO@EXPEDITIONONE.BIZ
801-627-2921

This product contains chemicals known to the state of California to cause birth defects or other reproductive harm. For more information go to www.p65warnings.gov

INSTALL GUIDE

ALL

LIGHTPORTS

To give you a wide range of options from various brands and designs, the light ports were designed to be as universal as possible. Not all mounts or designs will fit exactly and may require the use of shims, spacers, light manufacture mounts or different hardware to mount. Reuse of OEM light is limited to select bumpers and will come with provided hardware to reinstall. It is recommended that lights be purchased with the bumper in hand to gain the best fitment. We **DO NOT** manufacture the lights, provided wiring, or instructions on how to connect to the OEM harness.

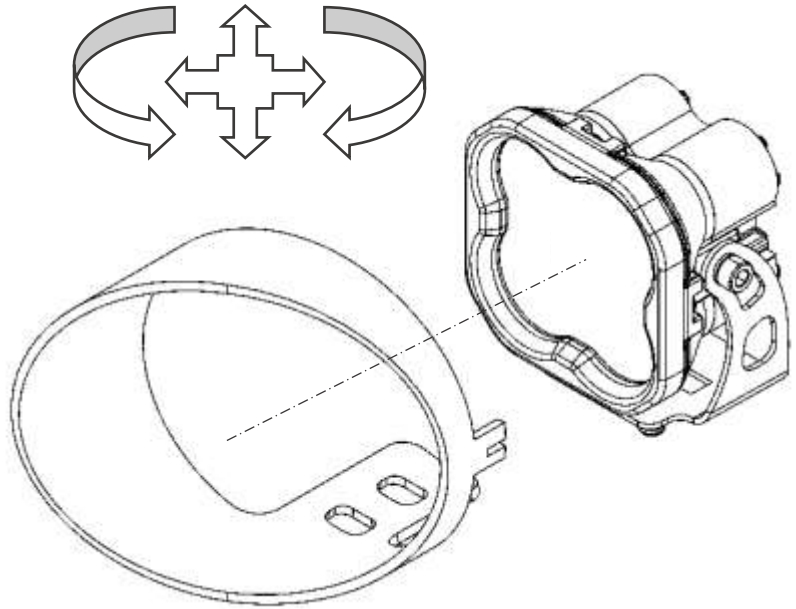

EXAMPLE SHOWN – LIGHT PORTS VARY

WINCHES

We use the most common bolt patterning but cannot guarantee your particular winch will fit. Because there are so many different brands on the market for winches, we typically recommend you wait until you have your bumper in-hand and ideally even installed to have specific measurements for best fit for your particular application. Integrated and Non-Integrated solenoid fitment varies by vehicle, model, and engine. Non-integrated solenoids will need to be relocated to an open location with in the bumper, engine bay, or other open location. We **DO NOT** provide mounts or instruction for relocation of the solenoid. Most bumpers use a foot forward mount and will require the winch to be clocked (see winch manufacture for details). Winch plates or direct mounting locations will be provided with the bumper, see install guide for details. See winch manufacture for hardware, associated parts, or fairleads. . We **DO NOT** manufacture the winch, provided wiring, or instructions on how to connect to the vehicles power.

AFTERMARKET or OEM PRODUCTS

We **DO NOT** guarantee fitment or installation of any aftermarket, third party or OEM parts, accessories, or hardware. This includes items such as lighting, winches, skids, lifts, suspension, and accessory mounts. Access to all brands, manufactures and country of origin specific parts is limited or impossible during the product development stage and subsequent new or modified revisions of said products including OEM design changes or refreshes. It is recommended you have the product in hand and installed before modifying with other aftermarket parts. Consult forums or other sources to gain any first hand knowledge of other products others have installed.















INSTALL GUIDE

ALL

HARDWARE

Please review for details and installation. Figures or data may vary. Leave all accessible hardware loose for installation and tighten all hardware after everything is installed on the vehicle. Check and retighten all hardware after the first 100 miles and/or after off roading. **Some hardware locations do not require being tightened to spec due to there design, location or material attachment (including rubber, plastic, and aluminum).** Over tightening may break or damage parts. Torque spec may vary, amounts listed are generic.

HARDWARE		TORQUE SPEC – FT.-LBS.	
SIZE	SOCKET WRENCH	GRADE 5 M- 8.8	GRADE 8 M – 10.9
#8	1/4"	X	
#10	5/16"		
1/4"	7/16"	6-8	9-10
5/16"	1/2"	13-14	18-20
3/8"	9/16"	23-26	33-37
7/16"	5/8"	37-41	52-58
1/2"	3/4"	57-64	80-90
9/16"	13/16"	82-91	115-129
5/8"	15/16"	112-118	159-180
3/4"	1-1/8"	200-223	282-315
7/8"	1-5/16"	322-355	454-501
1"	36MM	X	
M6	10MM	9-10	13-15
M8	13MM	22-24	32-35
M10	15MM	44-49	64-72
M12	18MM	76-83	112-123

TYPES OF HARDWARE		
		
HEX CAP BOLT	WASHER	NYLOC NUT
		
BUTTON HEAD BOLT	FENDER WASHER	HEX NUT
		
CARRIAGE BOLT	INTERNAL TOOTH	JAM NUT
		
SOCKET CAP BOLT	CLIP NUT	ACORN NUT
		
FLAT HEAD SCREW	RIVET NUT	COUPLING



GRADE5



CLASS8.8



GRADE8



CLASS10.9

NOTE - Extra hardware may be left over due to model or option specific items that may not be required for the install.

INSTALL GUIDE

EXP262

WINCH & FRAME MOUNTS

A Winch Mount 1

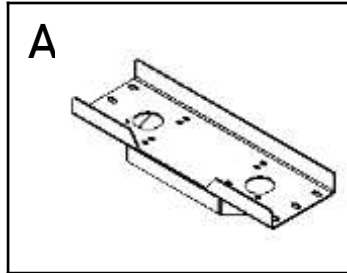

B Winch Mount Brackets 2

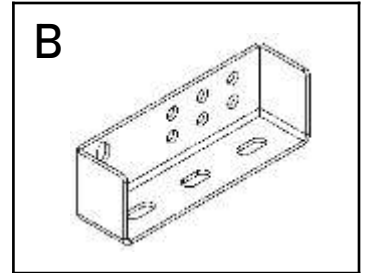

C Front Reinforcement Brackets 2

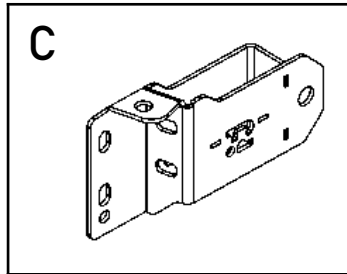

D Frame Spacer 2

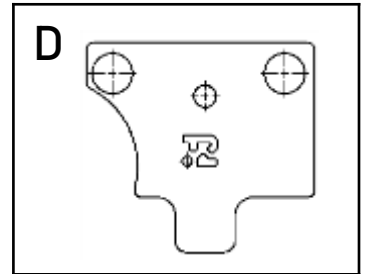

BUMPER MOUNTS

E Bumper Mount Bracket 2

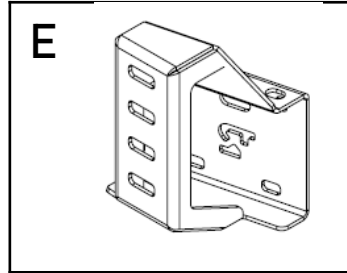

F Mount Shim Thick 2

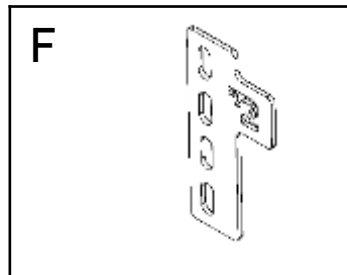

G Mount Shim Thin 2

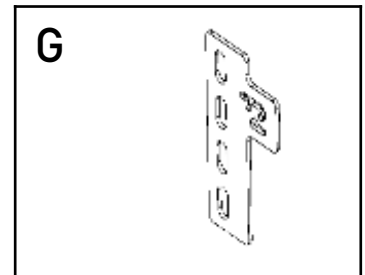

WINCH & FRAME MOUNT HARDWARE

3/8"-16 X 1 1/4" Hex Cap Bolt	8
3/8"-16 Nyloc Nut	8
3/8" USS Washer	16
1/2"-13 X 1 1/2" Hex Cap Bolt	22
1/2"-13 Nyloc Nut	22
1/2" SAE Washer	44
3/4" - 10 X 4 1/4" Hex Cap Bolt	2
3/4" - 10 Nyloc Nut	2
3/4" USS Washer	4

BUMPER HARDWARE

5/16" USS Washer	1
1/2"-1 X 1 1/2" Hex Cap Bolt	8
1/2"-13 Nyloc Nut	8
1/2" USS Washer	16

MISC HARDWARE

Sensor Bezels	4
Sensor Bezel Ties	4
Double Side Tape	1

NOTE - Extra hardware may need to be removed due to model or option specific items that were not be present for the models and year specific vehicles used in our install. Check for extra connections before removing hardware.

1 - REMOVE OEM BUMPER HARDWARE

Remove the front bumper OEM hardware from the front wheel wells on each side of the vehicle. Extra locations may need to be unbolted to flex the fender trim (or completely remove the trim) for bumper removal, access and installation.



Unbolt the OEM hardware from the top of the grille as circled below. Save hardware as it will be reused.

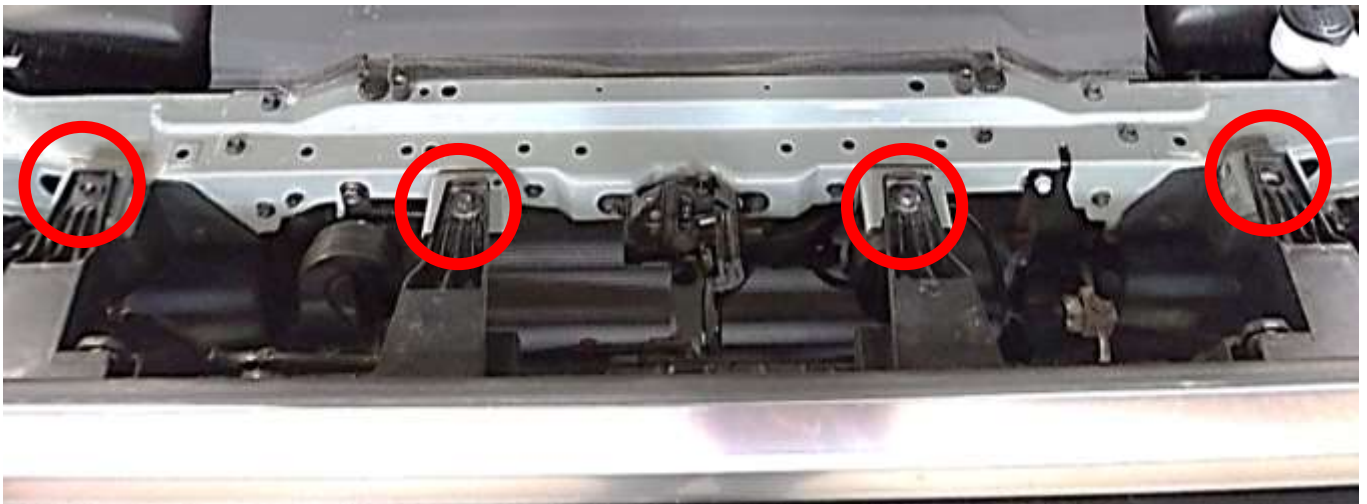

2 – WIRING CONNECTIONS

Disconnect all wiring at the top of the grille,, grille shutter and main harness connect point. The OEM lights and sensors should remain attached to the bumper as part of the harness.



3 – BUMPER REMOVAL

Check for any remaining hardware connecting the bumper. Remove the bumper by pulling it away from the corner near the wheel wells.

4 – FRONT SPOILER REMOVAL

With the bumper removed, disconnect the wiring for the front spoiler motor. Unbolt all hardware and remove the motor and associated spoiler .The motor will be separated and remounted later to avoid setting a check engine code. The spoiler can't be remounted.



5 – CROSS MEMBER REMOVAL

Unbolt and remove the cross member as shown below. Save OEM hardware to be reused in mounting.

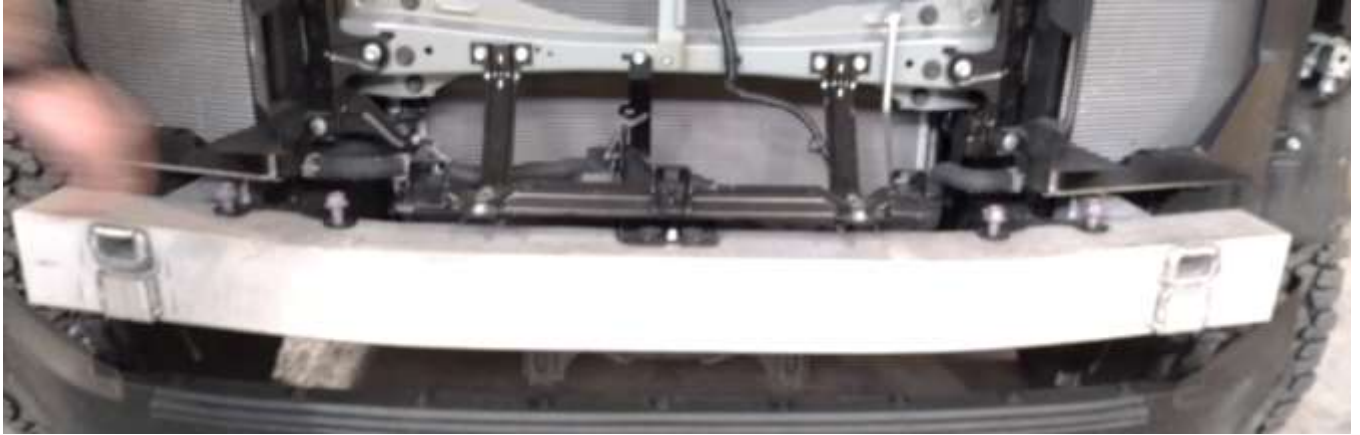

Remove the lower grace brace and remaining fixtures from the area of the cross member.



6 – GRILLE SHUTTER REMOVAL

Unbolt grill shutter assembly from the grille and disconnect from the wiring harness. The center section will need to be pried open to gain access to mounting hardware and the motor once removed.

NOTE – The grille shutters may remain in place if no winch is mounted or if a compact option with a solenoid relocation is used. Clearances, grille trimming, and remounting of will vary from the rest of the install. We can't confirm fitment of all items if this route is selected. See Winch disclaimer for details

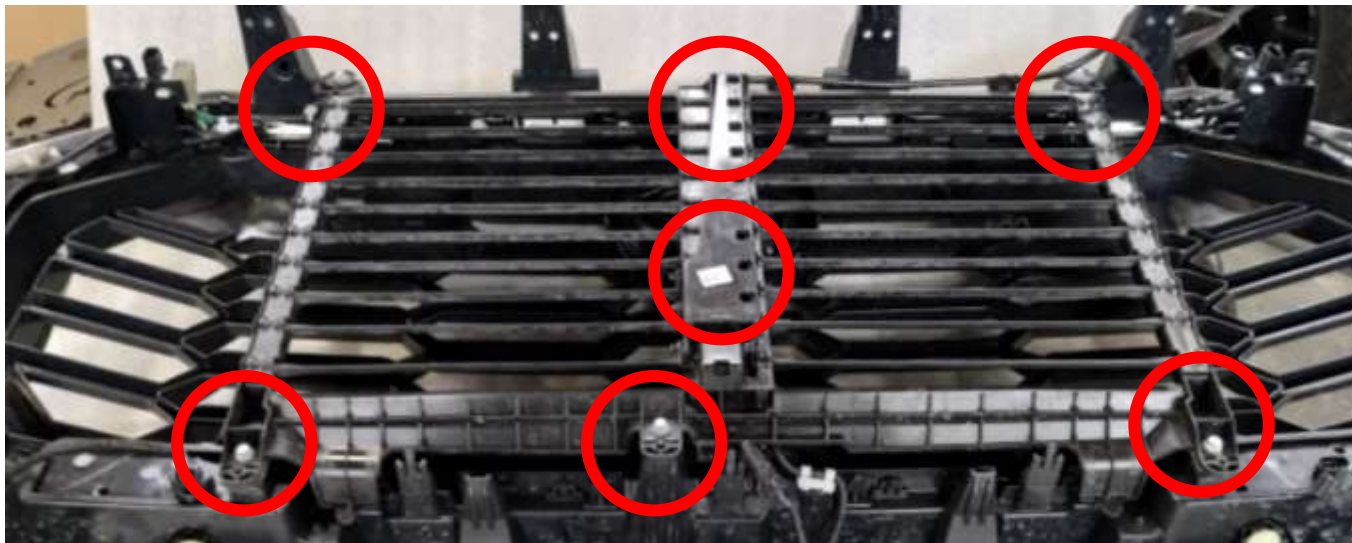

6 – CONTINUED

Cut apart the grill shutter assembly as shown below. Remove the wiring and motor inside as these will be reinstalled.

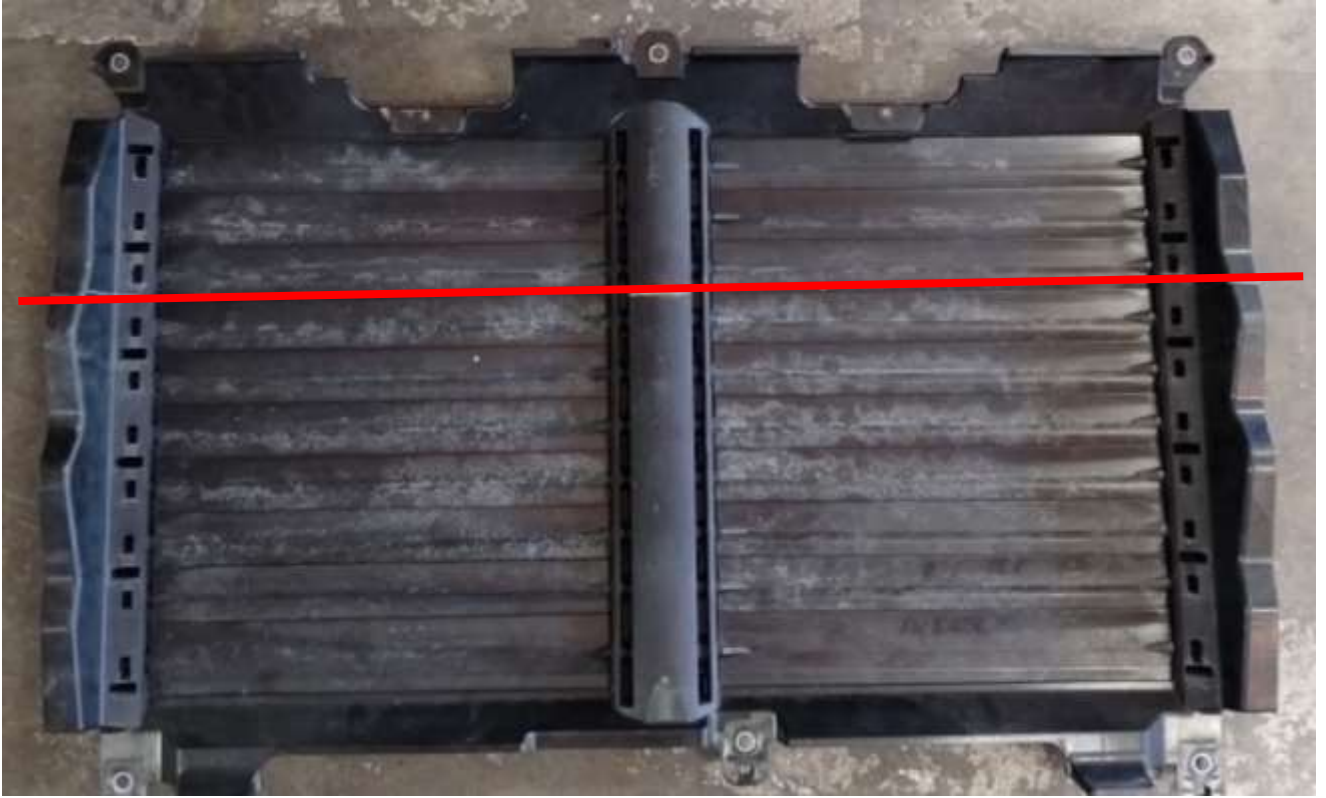

The cut section needs to match the mounting bracket piece as shown on the ends. With this part in place, align the triangle-shaped mount up with its shared location on the larger bracket. Mark the location where it will mount to the grille shutter and drill. Attach using the provided $\frac{1}{4}$ hardware. Repeat the same operation for the larger bracket on the side locations. Reinstall the wiring and motor

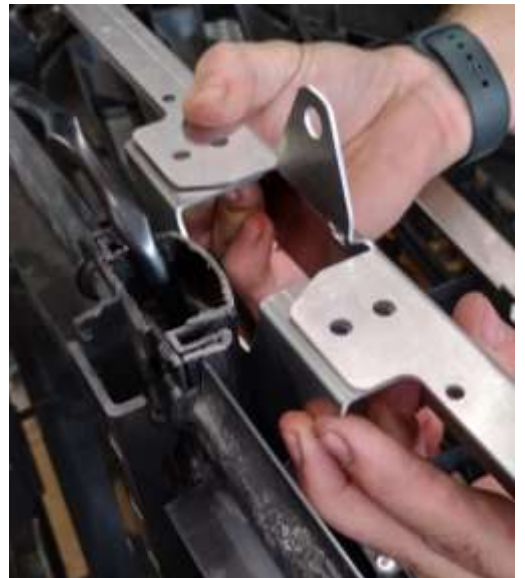
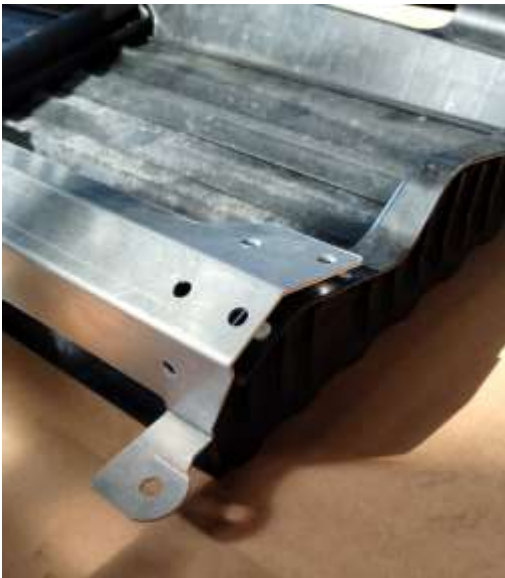



With the mounts installed. The grille shutter can now be installed into the original OEM grille location.



7 – WIRE LOOM REMOVAL

Unclip the wiring loom from the grille. Disconnect the parking sensors from the bezels. Be care to not break any clips or parts of the bezel as they will be reused in the new bumper. Unplug the fog lights and ACC at this time. Note the position of sensors and plug locations for correct reinstallation position.



8 – GRILLE TRIM REMOVAL

Undo the clips and pull off the lower front fascia panel. Remove the OEM lights and the remaining lower grill side trim. Save hardware as some parts will be reinstalled after trimming.

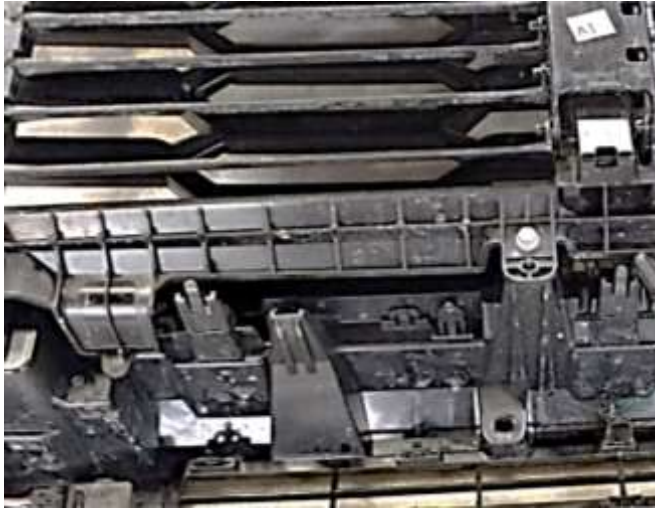

8 – CONTINUED

The bumper as shown removed of trim and ready for cutting.



9 – BUMPER TRIMMING (RANGEMAX ULTRA ONLY)

Trim the bumper as shown. Measure 1" above transition face on the side of the bumper and cut towards the center of the OEM light area. Cut horizontally across the grill following the transition edge of the grill line. Cut as needed.. Extra may be required once the bumper is fitted to allow for body and frame flex or variations in OEM product and manufacturing. The removed grille fascia pieces and fender trim will need to be cut to match once the main bumper is cut.

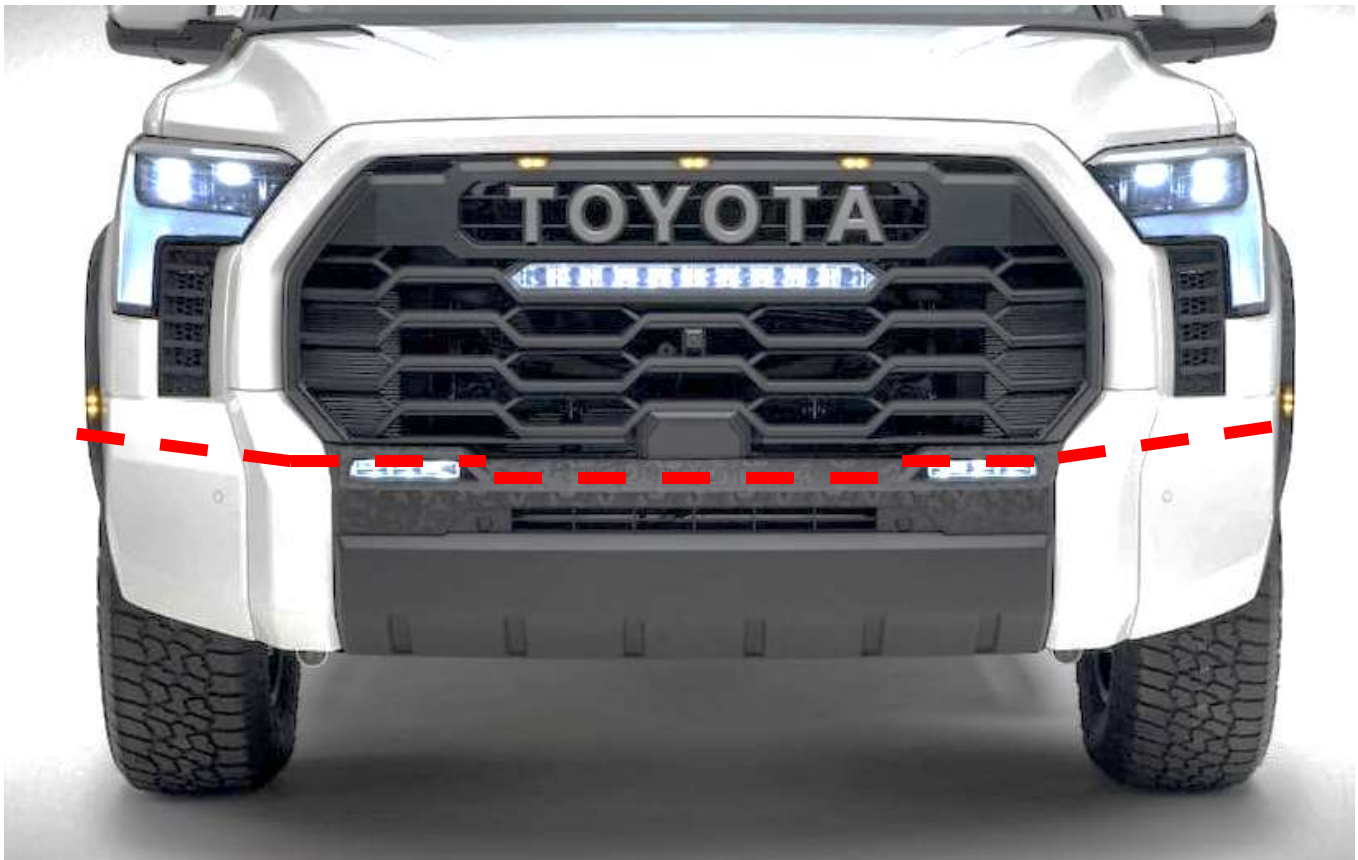

9 - CONTINUED

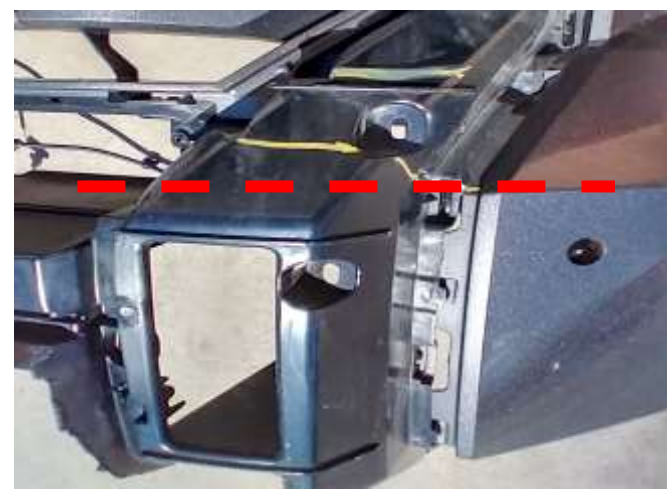

10- FRAME MODIFICATION (IF APPLICABLE)

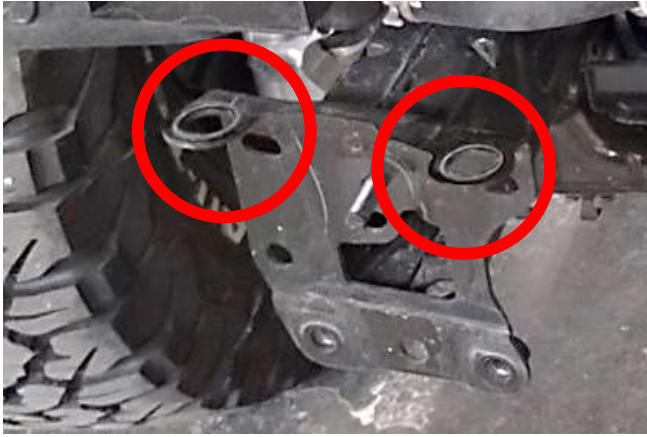

NOTE

The OEM frame tops may be bent or have undersized holes.

This may require one of the options below

- 1 - Bend them back to level
- 2 - Drill holes to fit 1/2" hardware (recoat surface)
- 3 - Use 3/8" hardware in place of 1/2" if needed

11 - FRAME SPACER

Attach the provided frame spacer as shown.



12 – REINFORCEMENT BRACKET INSTALLATION

Attach the reinforcement bracket next to the frame as shown. Mount using the provided 3/4" hardware.

Leave all hardware loose for adjustment.

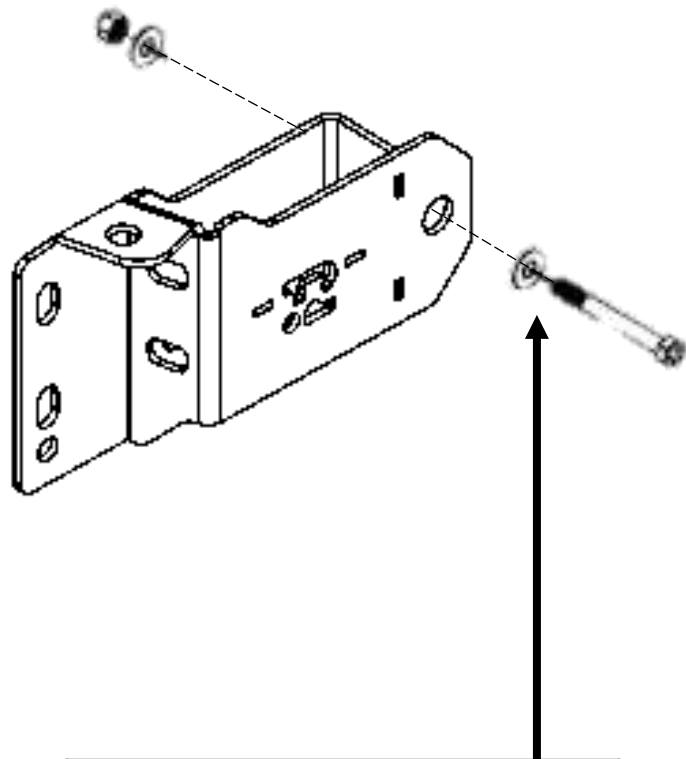
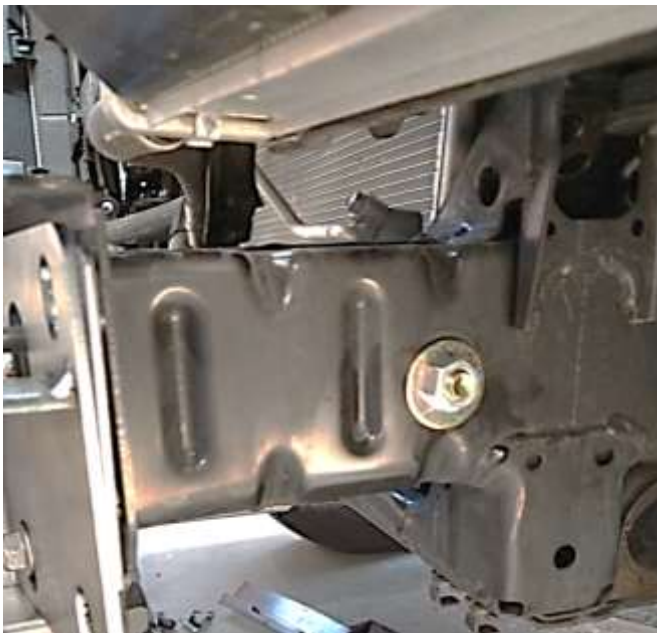

3/4" - 10 X 4 1/4" Hex Cap Bolt	2
3/4" - 10 Nyloc Nut	2
3/4" USS Washer	4

13 – REINFORCEMENT BRACKET INSTALLATION

Attach the bumper mount bracket next to the frame and reinforcement bracket as shown. Mount using the provided 3/8" & 1/2" hardware and OEM bolts. Leave all hardware loose for adjustment.

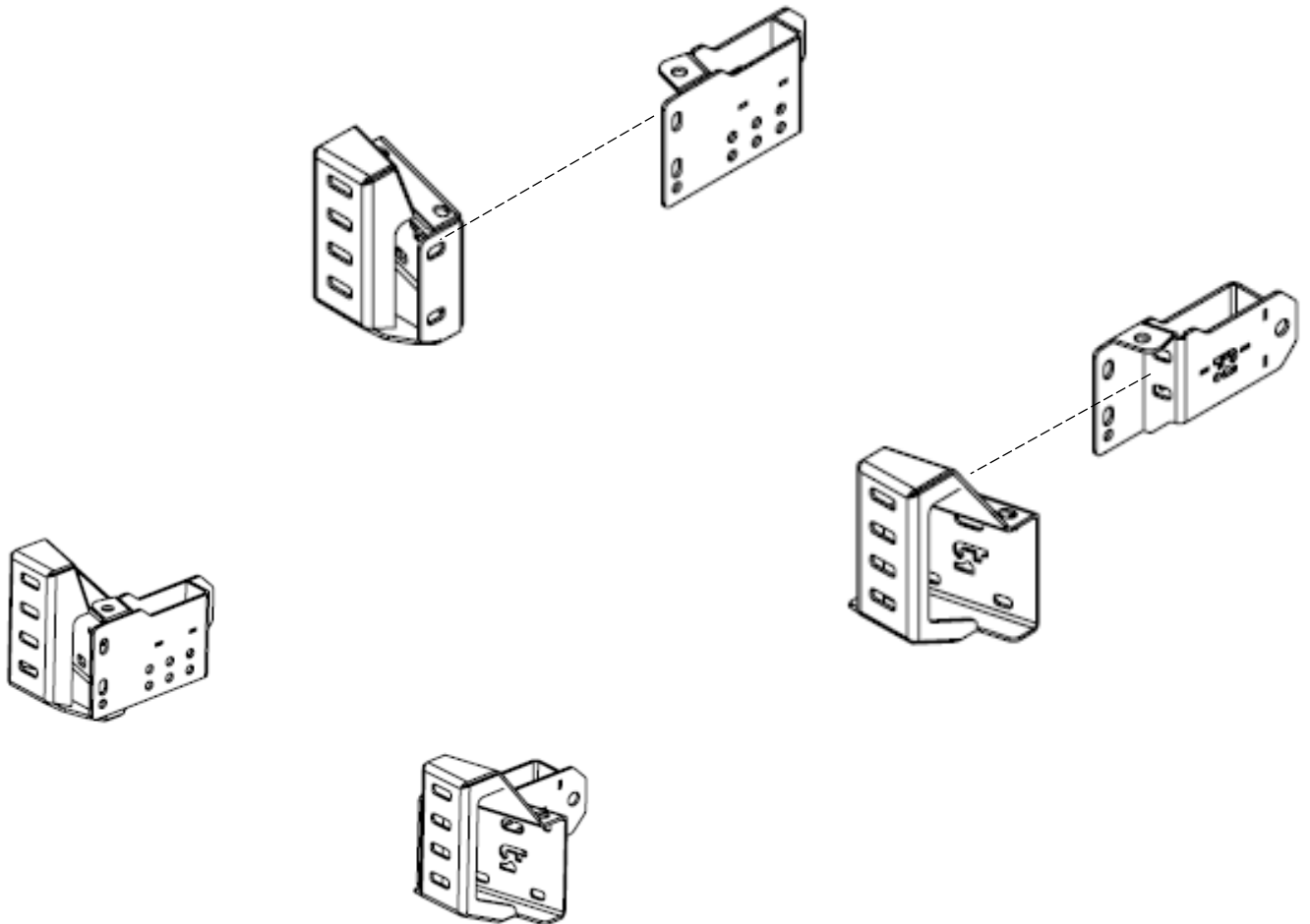

13 - HARDWARE DIAGRAM

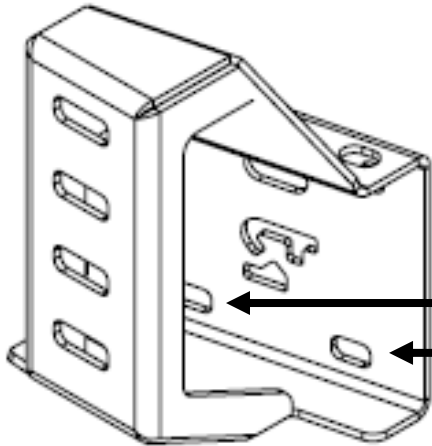

OEM HARDWARE	4
--------------	---

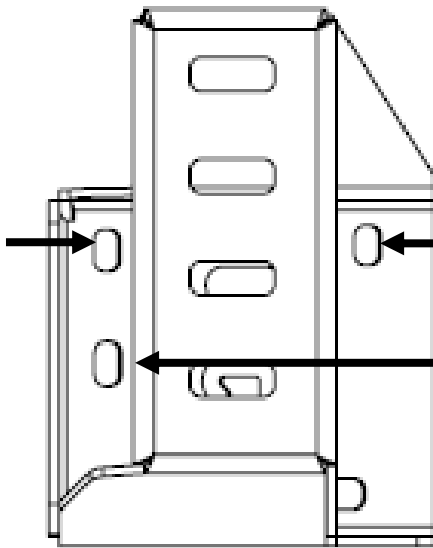

3/8" - 16 X 1 1/4" Hex Cap Bolt	4
3/8" - 16 Nyloc Nut	4
3/8" USS Washer	8

1/2" - 13 x 1 1/2" HEX CAP BOLT	2
1/2" - 13 NYLOC NUT	2
1/2" USS WASHER	2

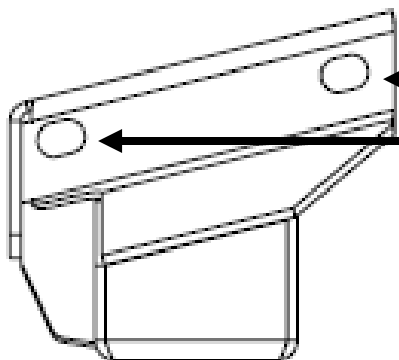

1/2" - 13 x 1 1/2" HEX CAP BOLT	4
1/2" - 13 NYLOC NUT	4
1/2" USS WASHER	8

11 - FRAME MODIFICATION (IF APPLICABLE)*

3/8" - 16X 1 1/4" Hex Cap Bolt	4
3/8" - 16 Nyloc Nut	4
3/8" USS Washer	8

14 – WINCH MOUNT BRACKET INSTALLATION

Attach the winch mount bracket next to the bumper mount and reinforcement bracket as shown.

Use the provided 1/2" hardware. Leave all hardware loose for adjustment.

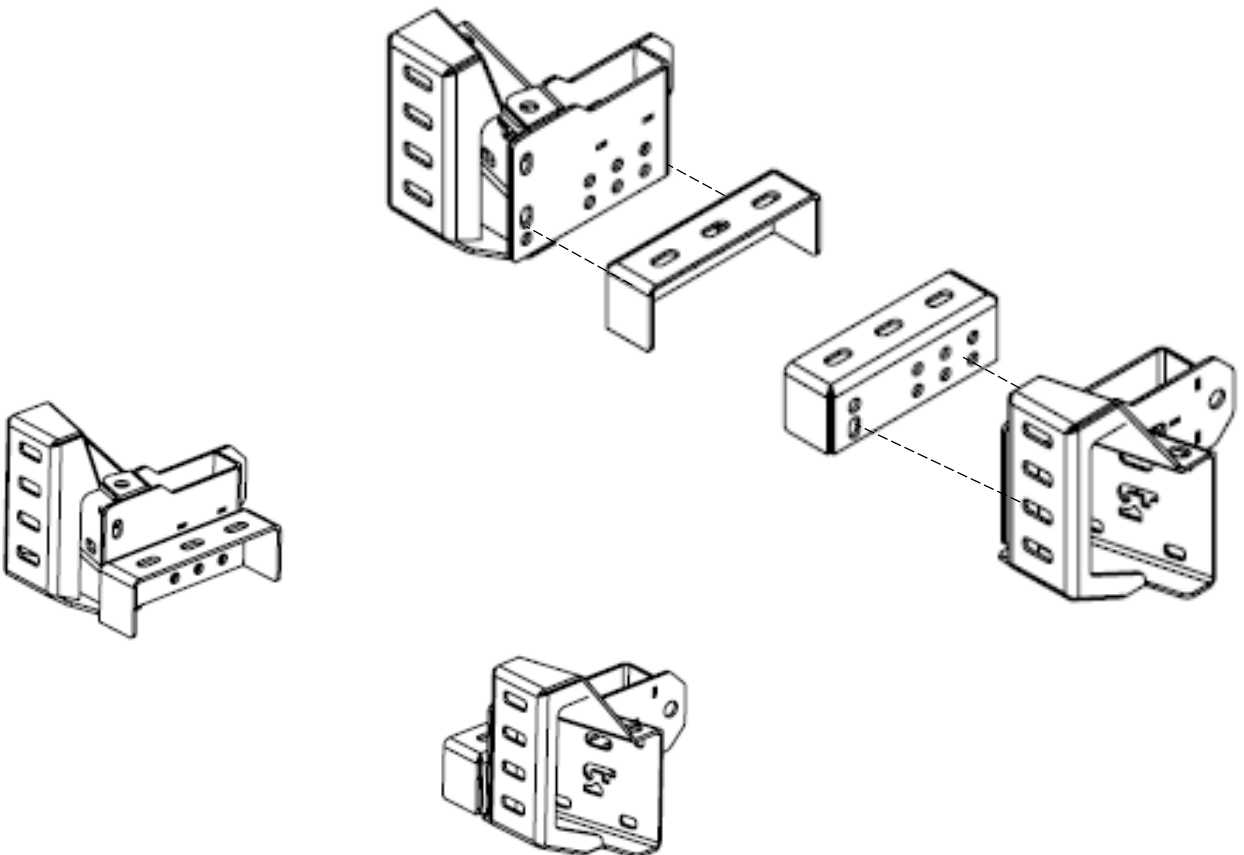

14 - HARDWARE DIAGRAM

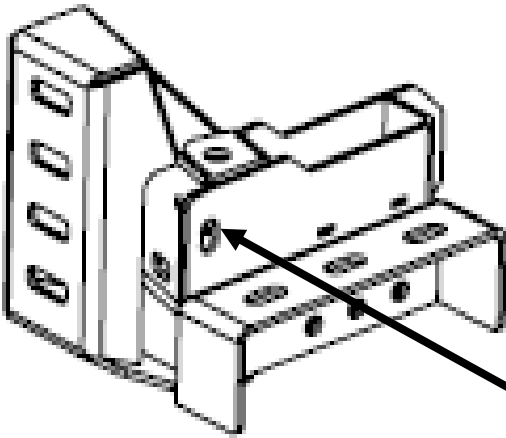

1/2" - 13 x 1 1/2" HEX CAP BOLT	2
1/2" - 13 NYLOC NUT	2
1/2" USS WASHER	4

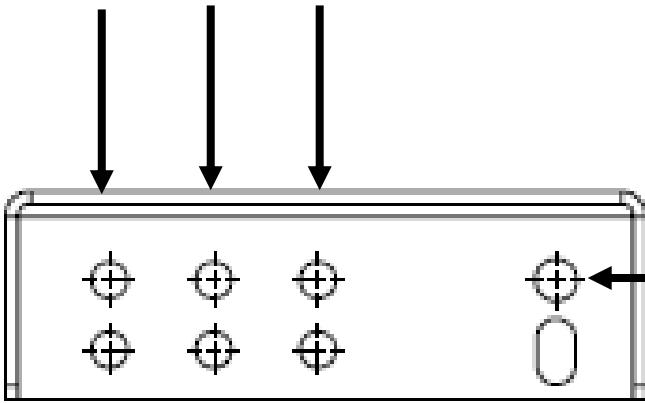

1/2" - 13 x 1 1/2" HEX CAP BOLT	8
1/2" - 13 NYLOC NUT	8
1/2" USS WASHER	16

MOUNT IN A TRIANGLE PATTERN

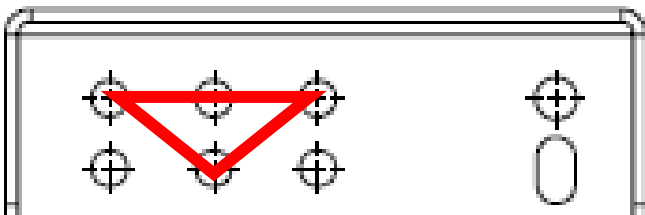
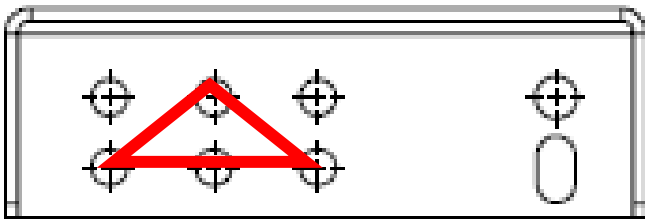

15 – WINCH MOUNT INSTALLATION

Place the winch mount onto the winch mount bracket as shown. Mount with the provided 1/2" hardware

Leave all hardware loose for adjustment.

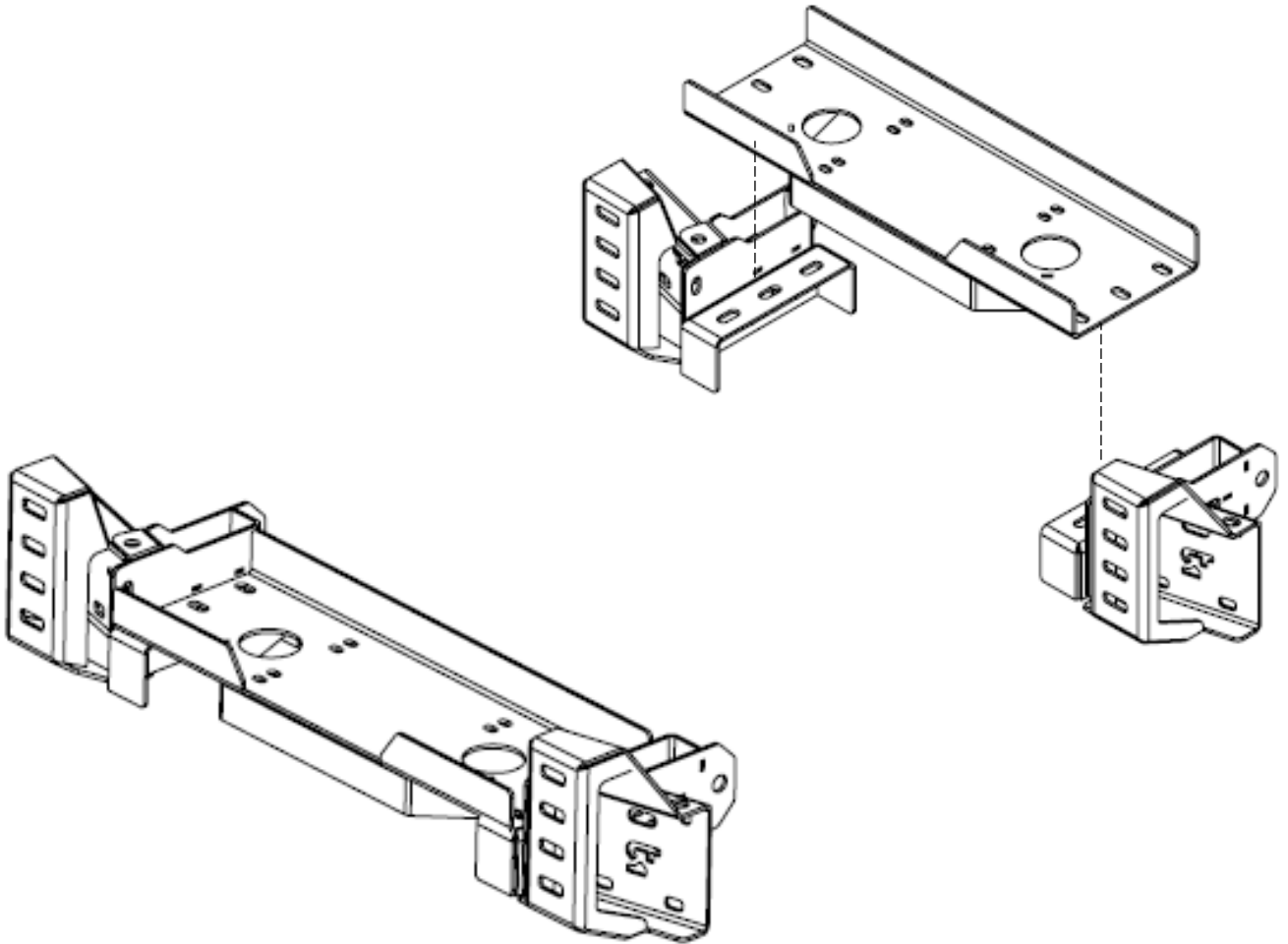

	←	1/2" – 13 x 1 1/2" HEX CAP BOLT	6
	←	1/2" – 13 NYLOC NUT	6
	←	1/2" USS WASHER	12

16 – TIGHTEN HARDWARE

Adjust the winch mount to its desired location and TIGHTEN HARDWARE. Check that all hardware is tightened including all brackets and mounting locations

17 – WINCH INSTALLATION

Mount the winch at this time using the winch manufacture provided hardware. This will mount directly to the winch mount. Adjust as needed, and see winch section for details

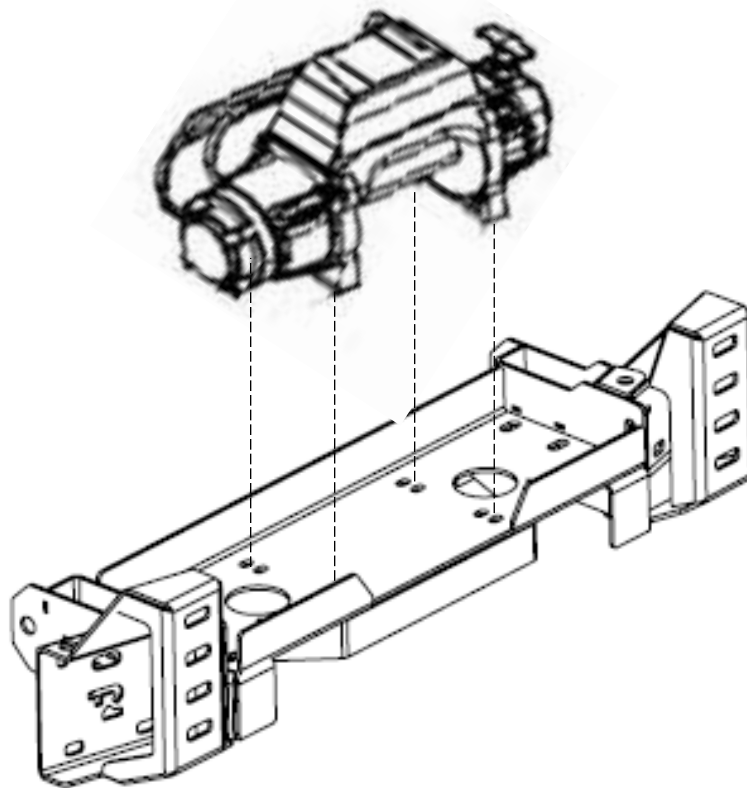
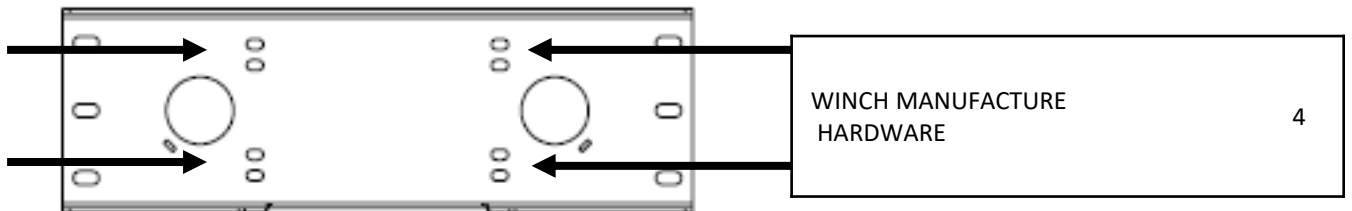

18 – SPOILER MOTOR RELOCATION (IF APPLICABLE)

Unbolt and relocate the horn as shown. Before for reinstalling the spoiler motor, bend the tab back from the old horn location. Next the motors housing will need to be trim of tabs or gussets for clearance and weight. Once trimmed reinstall the motor into the horns original location. Don't over tighten and use the provided washer to prevent cracking of the housing

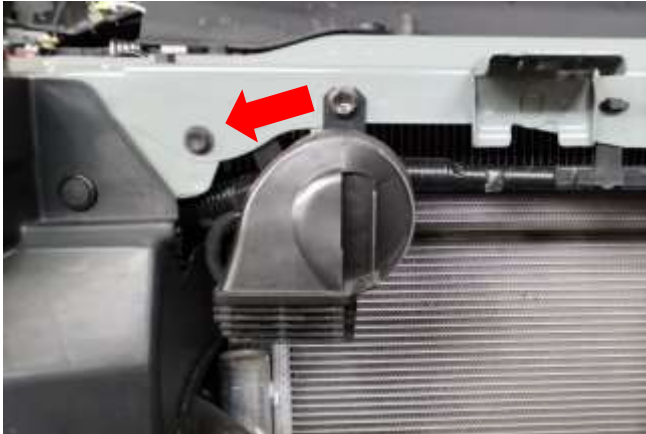

19 – OEM BUMPER REINSTALLATION

Loosely reinstall the wiring harness in the grille area matching the positions of sensors and plug locations from before, this will position the harness once the bumper is installed. Make sure wiring or other items including the winch rope are clear of pinch points for installation.. Reinstall the OEM bumper. Mask off the area around the grill and cut lines for installation of the bumper.



20 – BUMPER MOUNTING

Mount the bumper as shown using the provided 1/2" hardware. Center the bumper with the vehicle and align gaps between the body and bumper to your preference before mounting. Mount the front bumper using the OEM hardware as shown below. Leave all hardware loose for adjustment.

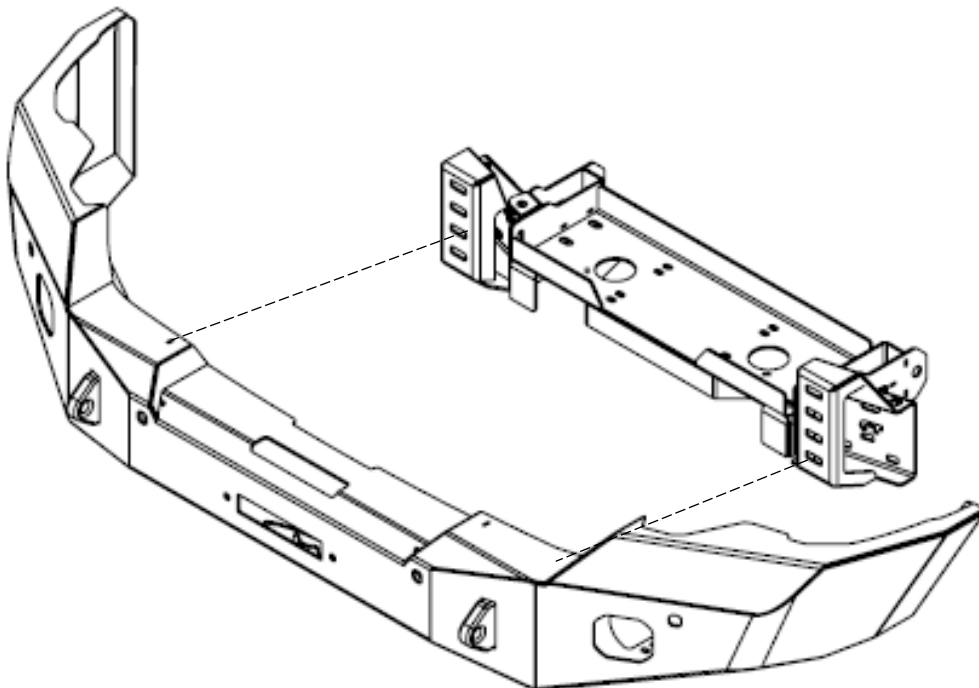

20 – HARDWARE DIAGRAM

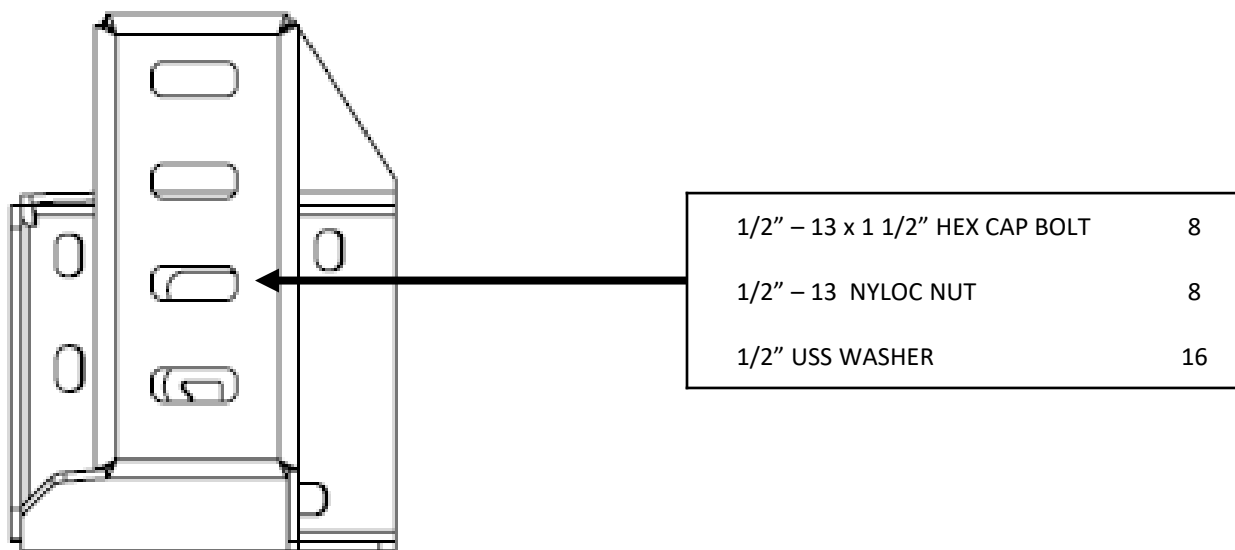

Use the provided spacers if necessary to shim the bumper. The OEM plastic and frame will vary in Relation to each other and the bumper. Adjust and use as need when mounting.

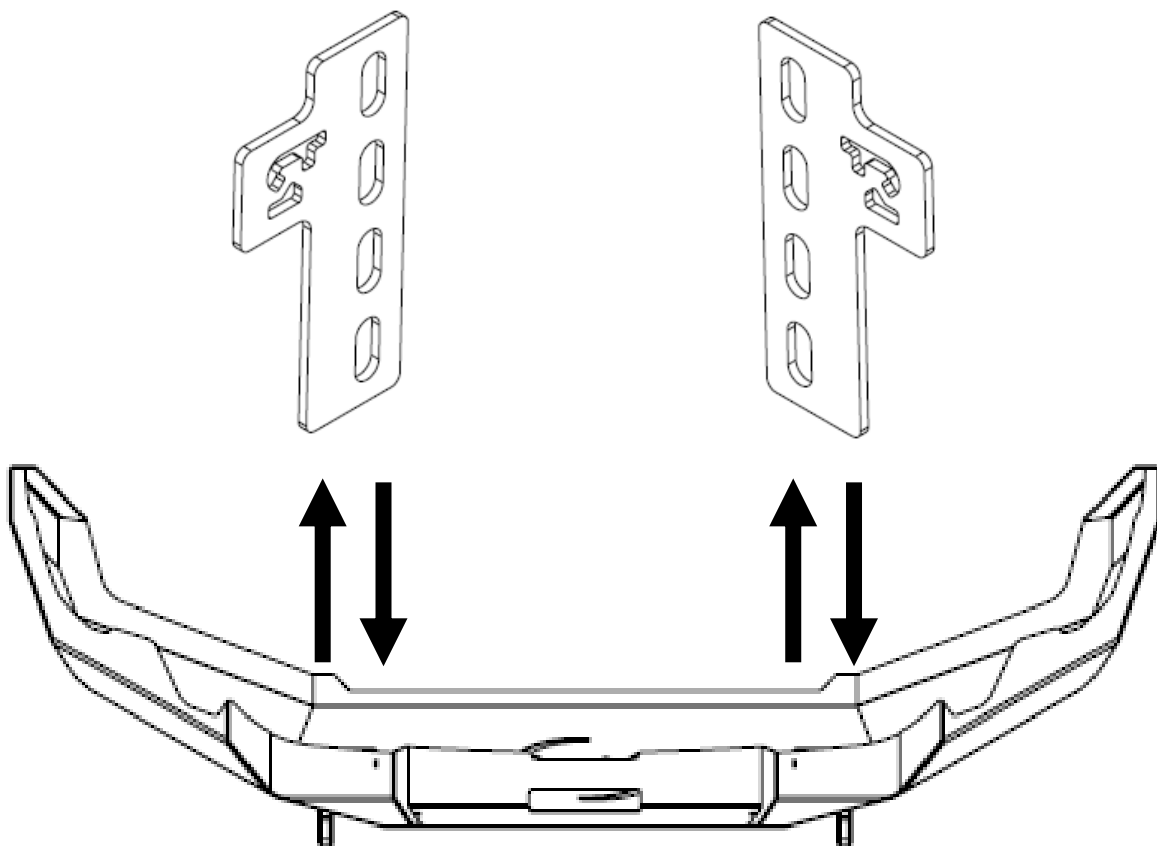

21- WIRING HARNESS

Reconnect the wiring harness into the new bumper. Place all wiring out of the way of mounting points and hardware locations. Check that the wiring loom connectors match there original points of connection per each side of the vehicle and ACC sensor. Install the new bezels and connect the sensors. When using the provided replacement rubber bezels use WD40 and align the fat edge directional to the pointed surface when fitting. Secure the wiring loom.

22 – TIGHTEN HARDWARE

Adjust the bumper to its desired location and **TIGHTEN HARDWARE**. Check that all hardware is tightened including all brackets and mounting locations. Reconnect the parking sensor wiring harness and other connections to the vehicles electronics and secure all loose wiring. Check that everything is working and adjust if needed before driving on the road.

ADDITIONAL LINKS

<https://www.exp-one.com/wp-content/uploads/2016/10/Proper-Care-and-Maintenance.pdf>

<https://www.exp-one.com/wp-content/uploads/2016/10/Paint-touch-up-instructions.pdf>

<https://www.exp-one.com/wp-content/uploads/2018/02/Exp-One-2016-TC-word-doc.pdf>

**TIGHTEN ALL HARDWARE AFTER EVERYTHING IS INSTALLED ON THE VEHICLE
CHECK AND RETIGHTEN ALL HARDWARE AFTER THE FIRST 100 MILES AND
AFTER OFF ROADING. CHECK REGULARLY**