



WINCH MOUNT BUMPER

2023+ GMC CANYON



INSTALL GUIDE

PLEASE READ ENTIRE GUIDE BEFORE INSTALLATION

Recommended that you read this entire install guide before installation. Check that all hardware is present before starting or scheduling an install. This guide is supplemental to mechanical knowledge and ability. Anyone not familiar with automotive installation should seek professional installation.

LAST UPDATE 11/19/24 v1



INSTALL GUIDE

IMPORTANT INFO/FAQ

INSTALL GUIDE

ALL

INSTALLATION HELP

Please review terms and conditions for details

Recommended purchaser review Welcome Guide at time of purchase for details

Care and Maintenance available at www.exp-one.com/resources

We do our best to offer timely assistance with your installation questions however as most of our team members are primarily engaged in the manufacturing process and packaging processes, we do not currently offer a tech for on-demand calls and inquiries. For the more technical installs or installs that are time-sensitive in nature, we would recommend our customers seek out the services of professional shops with experience specific to aftermarket bumpers that can better meet your needs. We are happy to make recommendations to you on shops familiar with our products in your area. We do our best to respond to installation questions within 24-48 hours of contact as much as possible. Long-distance problem assessment can be difficult, so photos and videos are often required for us to best assist you. We highly recommend your initial contact regarding installation questions include both close-up and full photos, detailed descriptions using our part descriptions as much as possible, and video. This enables us to better assist without having the ability to see the install difficulties directly and assist you as quickly as possible.

NOTE

Expedition One does not guarantee fitment with other aftermarket products, or reinstallation of take off OEM parts.

Expedition One is NOT RESPONSIBLE for damage to paint or powder coating, items assembled in error during installation or costs associated with install

OEM manufacture model refreshes/updates, factory build location and suppliers may cause variations in fitment or installation and can not be verified, vehicle to vehicle .

This product contains chemicals known to the state of California to cause birth defects or other reproductive harm. For more information go to www.p65warnings.gov

GSA# GS-30F-013CA

EXPEDITION ONE
113 N. 700 W. BUILDING 5C BAY 1
OGDEN, UT 84404
INFO@EXPEDITIONONE.BIZ
801-627-2921

This product contains chemicals known to the state of California to cause birth defects or other reproductive harm. For more information go to www.p65warnings.gov



INSTALL GUIDE

IMPORTANT INFO/FAQ

INSTALL GUIDE

ALL

WINCHES

We use the most common bolt patterning but cannot guarantee your particular winch will fit. Because there are so many different brands on the market for winches, we typically recommend you wait until you have your bumper in-hand and ideally even installed to have specific measurements for best fit for your particular application. Integrated and Non-Integrated solenoid fitment varies by vehicle, model, and engine. Non-integrated solenoids will need to be relocated to an open location with in the bumper, engine bay, or other open location. We DO NOT provide mounts or instruction for relocation of the solenoid. Most bumpers use a foot forward mount and will require the winch to be clocked (see winch manufacture for details). Winch plates or direct mounting locations will be provided with the bumper, see install guide for details. See winch manufacture for hardware, associated parts, or fairleads. . We DO NOT manufacture the winch, provided wiring, or instructions on how to connect to the vehicles power.

AFTERMARKET or OEM PRODUCTS

We DO NOT guarantee fitment or installation of any aftermarket, third party or OEM parts, accessories, or hardware. This includes items such as lighting, winches, skids, lifts, suspension, and accessory mounts. Access to all brands, manufactures and country of origin specific parts is limited or impossible during the product development stage and subsequent new or modified revisions of said products including OEM design changes or refreshes. It is recommended you have the product in hand and installed before modifying with other aftermarket parts. Consult forums or other sources to gain any first hand knowledge of other products others have installed.















INSTALL GUIDE

ALL

HARDWARE

Please review for details and installation. Figures or data may vary. Leave all accessible hardware loose for installation and tighten all hardware after everything is installed on the vehicle. Check and retighten all hardware after the first 100 miles and/or after off roading. **Some hardware locations do not require being tightened to spec due to there design, location or material attachment (including rubber, plastic, and aluminum). Over tightening may break or damage parts. Torque spec may vary, amounts listed are generic.**

HARDWARE		TORQUE SPEC – FT.-LBS.	
SIZE	SOCKET WRENCH	GRADE 5 M- 8.8	GRADE 8 M – 10.9
#8	1/4"	X	
#10	5/16"		
1/4"	7/16"	6-8	9-10
5/16"	1/2"	13-14	18-20
3/8"	9/16"	23-26	33-37
7/16"	5/8"	37-41	52-58
1/2"	3/4"	57-64	80-90
9/16"	13/16"	82-91	115-129
5/8"	15/16"	112-118	159-180
3/4"	1-1/8"	200-223	282-315
7/8"	1-5/16"	322-355	454-501
1"	36MM	X	
M6	10MM	9-10	13-15
M8	13MM	22-24	32-35
M10	15MM	44-49	64-72
M12	18MM	76-83	112-123

TYPES OF HARDWARE		
		
HEX CAP BOLT	WASHER	NYLOC NUT
		
BUTTON HEAD BOLT	FENDER WASHER	HEX NUT
		
CARRIAGE BOLT	INTERNAL TOOTH	JAM NUT
		
SOCKET CAP BOLT	CLIP NUT	ACORN NUT
		
FLAT HEAD SCREW	RIVET NUT	COUPLING



GRADE5



CLASS8.8



GRADE8



CLASS10.9

NOTE - Extra hardware may be left over due to model or option specific items that may not be required for the install.

1 - BUMPER REMOVAL

Undo the front fender line. Once undo this will allow access to the fender trim attachments. Take care not to break the clips (a small socket should help undo them). Once undone remove hardware and start moving towards the center of the vehicle.



Unbolt the rear of plastic fascia, also detach the grille by removing the plastic shroud and hardware.

Undo all wiring and check for connections before removing the bumper.



2 - FASCIA REMOVAL

Remove the clips and hardware holding the front plastic fascia along with the OEM fog lights. Lower fascia can be taken off at this time if installing the Filler and Skid plate combo



3 – OEM FASCIA TRIMMING

Cut out the center of the OEM fascia as shown below. Cuts do not need to be specific, only to allow for the Winch internal mount to have clearance and fitment of the winch mount over the outside. Trim and test fit as needed to your liking. Remount the fascia to the car and reinstall all OEM hardware once Winch Mount is fully installed



4 – REINFORCEMENT BRACKET INSTALLATION

Trim out the grill shutter housing as shown below in the first photo. Attach the provided tabs to the bracket using 1/4" hardware also relocate the top OEM clip nut to the tab. Mount the brackets to the inside of the frame as shown in the diagram using 3/8" Hardware.



1/4" - 20 X 3/4" Hex Cap Bolt	2
1/4" - 20 Nyloc Nut	2
1/4" SAE Washer	4



Reuse clip nut circled in 2nd photo

3/8" - 16 X 4" Hex Cap Bolt	4
3/8" - 16 Nyloc Nut	4
3/8" USS Washer	8

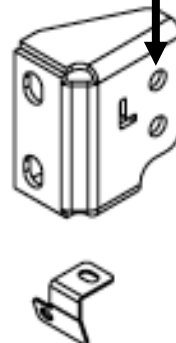

5 – CONTINUED

With the bracket install reattach the OEM bolt on the grille shutter to the tab. Next install the provided 3/8" clip nuts to the reinforcement bracket.

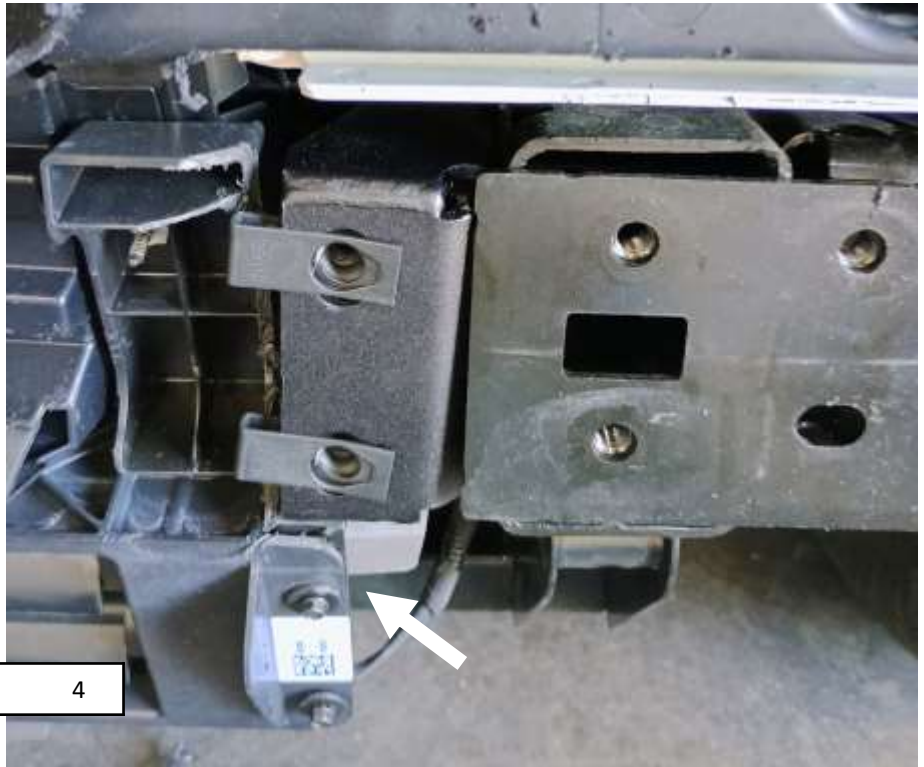

3/8" - 16 Clip Nut

4

6 – WINCH INSTALLATION

Mount the winch at this time using the winch manufacture provided hardware. This will mount directly to the winch mount. Adjust as needed. see winch section for details. Skip if no winch is to be installed.

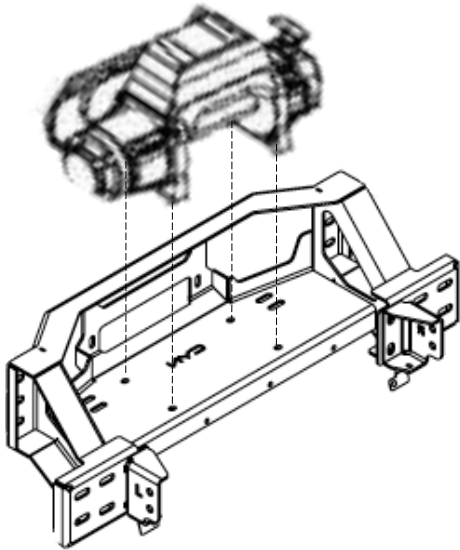

WINCH MANUFACTURE
HARDWARE

4



The plastic below the grille may need to be trimmed in some cases to allow the winch and its external parts to clear. **DO NOT** cut off completely as the tab openings on the edge of the grille will remount your OEM fascia piece

7 – WINCH INTERNAL INSTALLATION

Mount the internals as shown in the diagram below. Attach using the OEM hardware, 3/8" Hardware on the inner side and 1/2" hardware and provided nut retainer for the outside bottom corner. Mount and adjust as needed before tightening. RECOMMEND use Loctite

3/8" - 16 X 1 1/4" Hex Cap Bolt	4
3/8" USS Washer	4

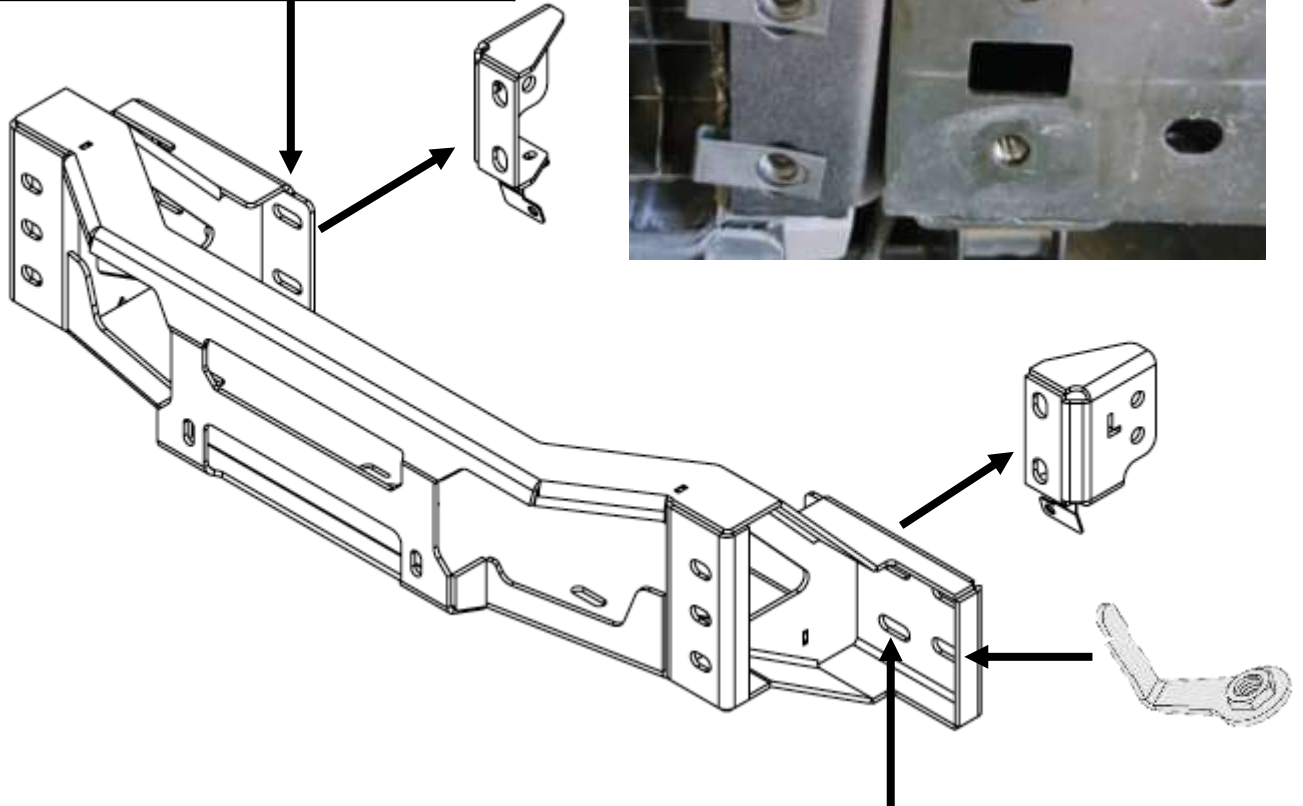

OEM Frame Bolts	6
1/2" - 13 X 1 1/4" Hex Cap Bolt	2
1/2" USS Washer	2
Bent Nut Retainer	2



8 – BOLT PLATE MOUNTING

Insert the provided 1/2" carriage bolts into the rectangle 3-hole bracket. Place inside the bumper and lock in with the provided lock rings

1/2" – 13 x 1 1/2" CARRIAGE BOLT	6
1/2" LOCK RING	6

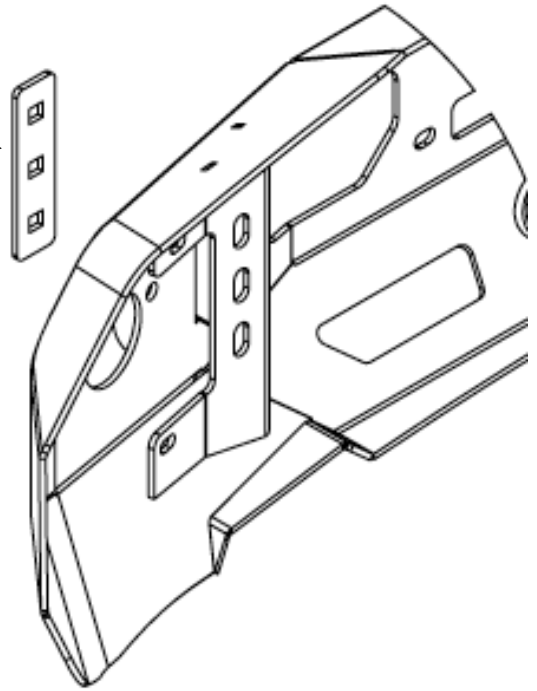

9 – OEM LIGHT INSTALLATION

Attach the OEM fog lights to the provided bracket using hardware. Mount to the bumper with 1/4" hardware and adjust as need with the opening. Aftermarket lights will require your own mounting solution.

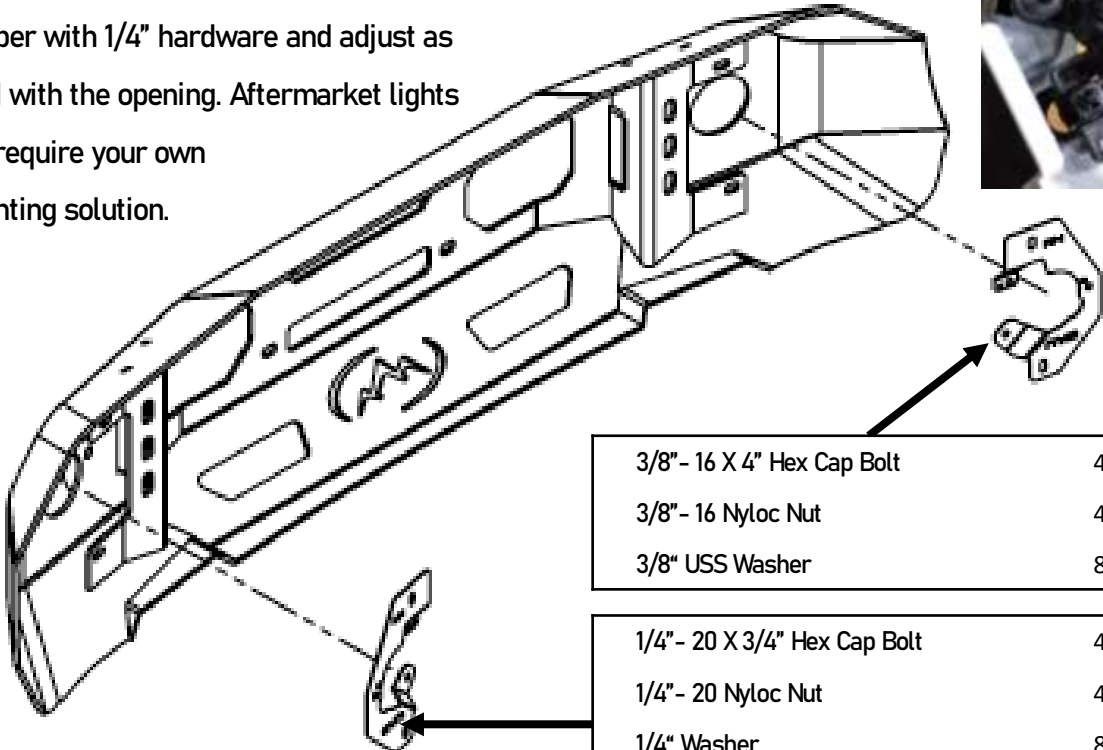

3/8" – 16 X 4" Hex Cap Bolt	4
3/8" – 16 Nyloc Nut	4
3/8" USS Washer	8

1/4" – 20 X 3/4" Hex Cap Bolt	4
1/4" – 20 Nyloc Nut	4
1/4" Washer	8

10 – WINCH MOUNT ATTACHMENT

Mount the winch mount to the internal mount. Attach using the provided 1/2" hardware. Adjust as needed and tighten. RECOMMEND use Loctite

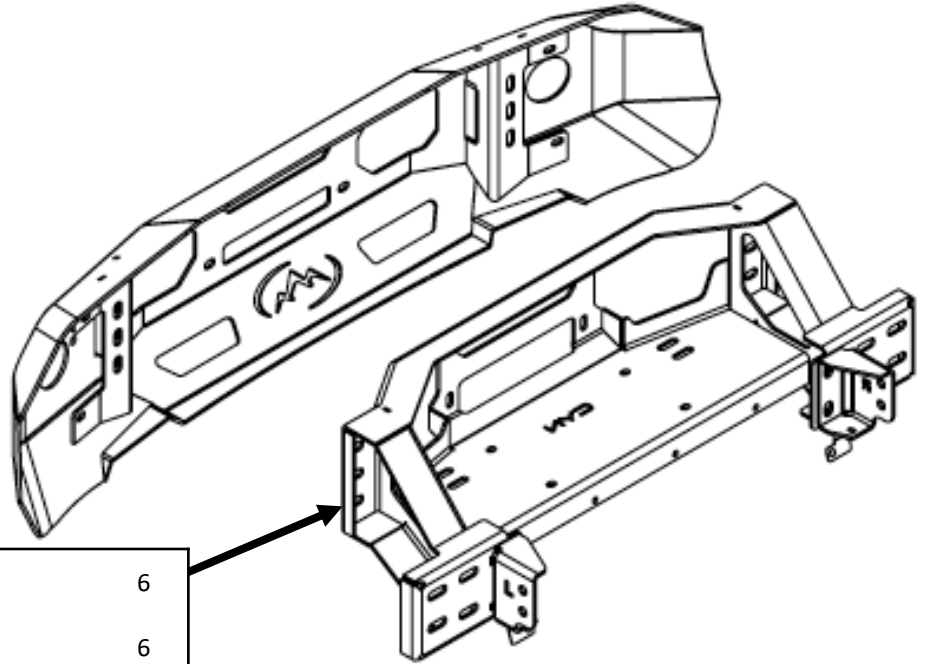

FILLER PLATE AND SKID OPTIONS

11 - WINCH MOUNT ATTACHMENT

Trim the end caps as shown straight across from the bottom of the bumper.

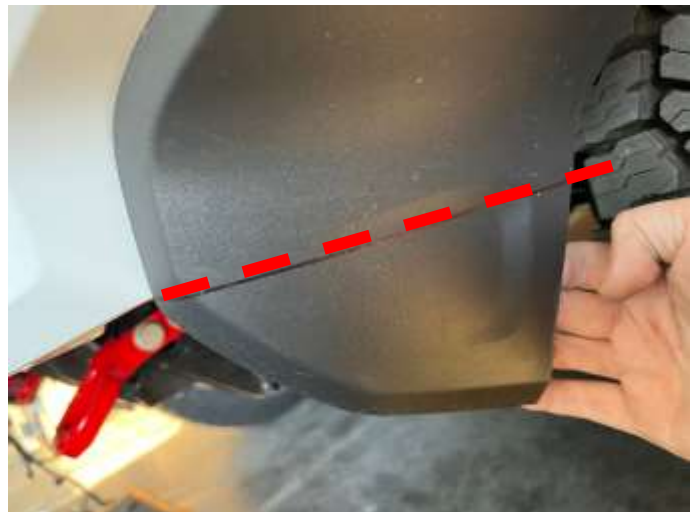

OPTIONAL

Filler plate can reuse the OEM clips for installation or use the provided 1/4" hardware.



12 - FILLER PLATE MOUNTING

Mount the filler plate together as shown below using the provided hardware. Match openings and drill locations as shown on the next page.

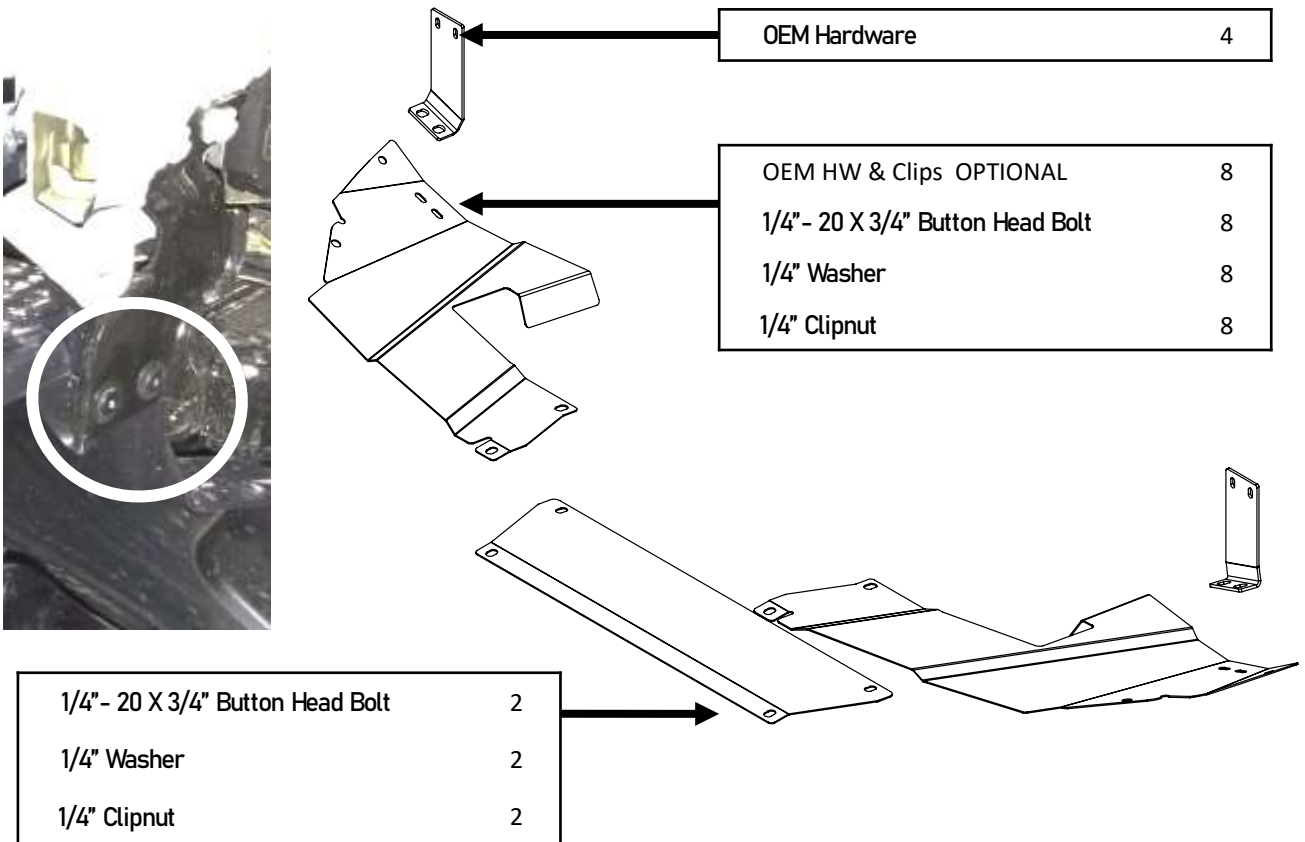



13 - SKID PLATE MOUNTING

Mount the skid to the front crossmember locations using the OEM clips and hardware. The hardware will need to be relocated to match the skid plates openings. Once mounted join the filler plate and skid together using the provided shim and 5/16" hardware. The OEM recovery hooks should remain in place but may vary.



5/16-18 X 3/4" Button Head Bolt	2
5/16"-18 Clip Nut	2
Rectangle Shim	2

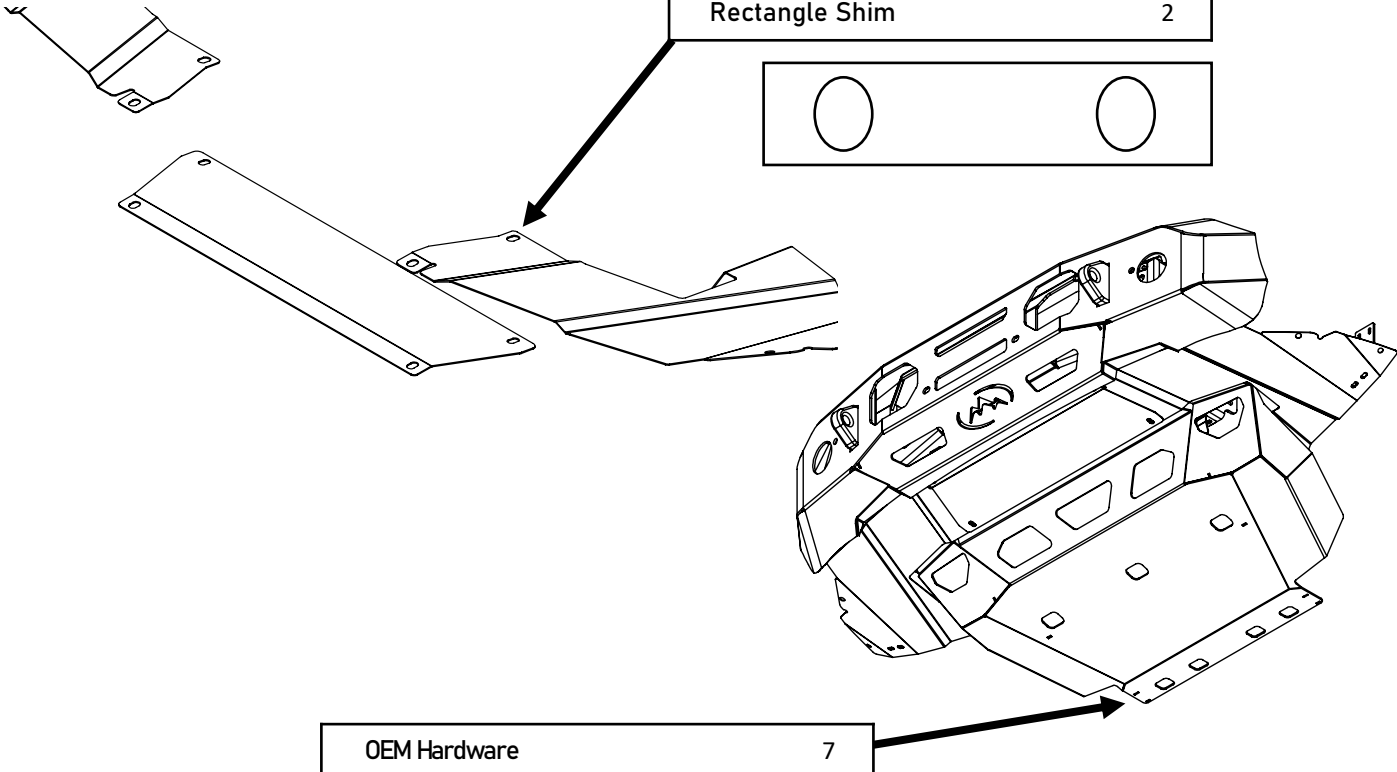

OEM Hardware

7

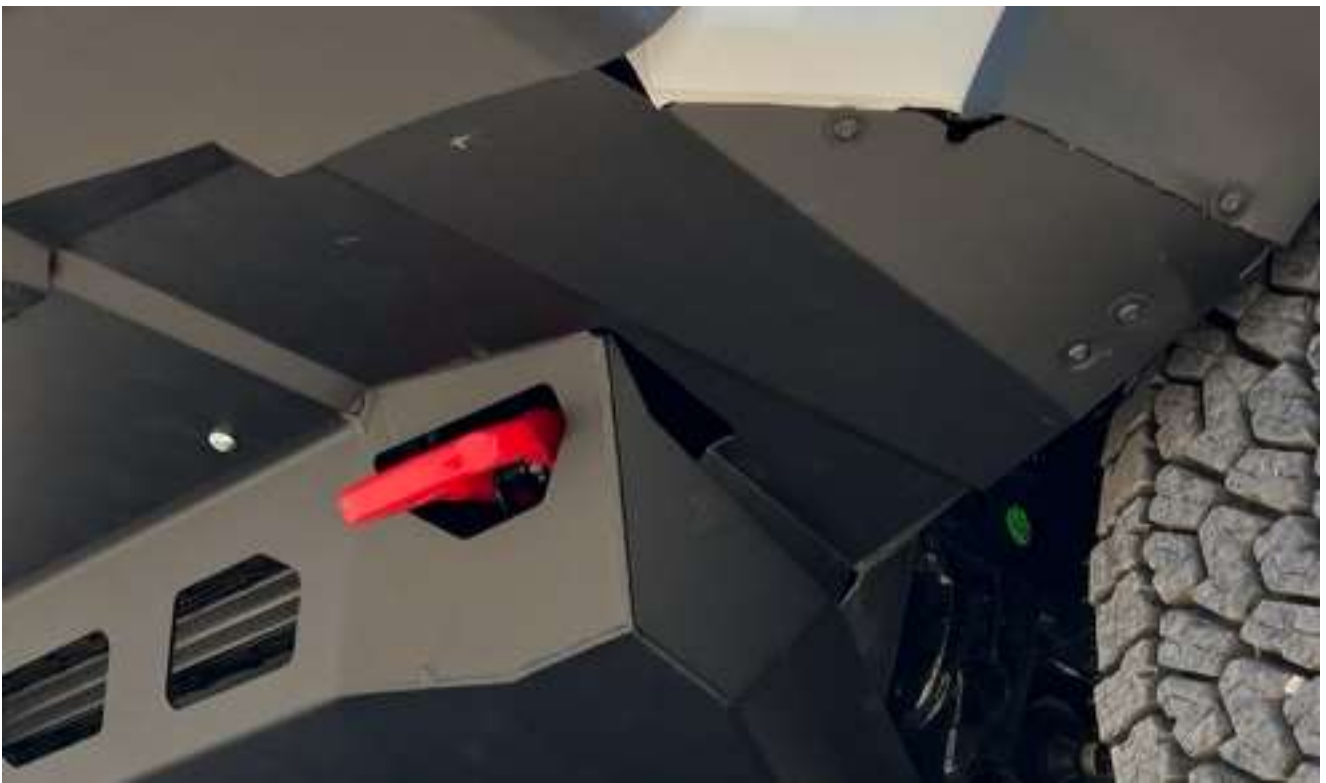

14 – TIGHTEN HARDWARE

Check that all hardware is tightened including all brackets and mounting locations. Reconnect the parking sensor wiring harness and other connections to the vehicles electronics and secure all loose wiring. Check that everything is working and adjust if needed before driving on the road.

ADDITIONAL LINKS

<https://www.exp-one.com/wp-content/uploads/2016/10/Proper-Care-and-Maintenance.pdf>

<https://www.exp-one.com/wp-content/uploads/2016/10/Paint-touch-up-instructions.pdf>

<https://www.exp-one.com/wp-content/uploads/2018/02/Exp-One-2016-TC-word-doc.pdf>

**TIGHTEN ALL HARDWARE AFTER EVERYTHING IS INSTALLED ON THE VEHICLE
CHECK AND RETIGHTEN ALL HARDWARE AFTER THE FIRST 100 MILES AND
AFTER OFF ROADING. CHECK REGULARLY**